

# The OPTO-IF

## A Digital Mode Interface Kit

By G3VFP of EZE(UK)

It was not that long ago in terms of our hobby when modes like, fax, packet, rtty and sstv seemed to be reserved for those who possessed the means to purchase and operate sometimes large, and expensive equipment. This began to change in the early '90s when software written for home computers began to replace the expensive hardware.

Programs such as HamComm allowed operation of CW, RTTY and a few other modes requiring only a few "junk-box" components to fabricate a simple comparator modem. Based upon the 741 op amp. JV FAX used the same modem to give us SSTV with amazing results.

These early DOS based programs were followed by variations on the same theme, but eventually gave way to Microsoft Windows based software, and since then there has been an explosion of digital mode software like Zakanaka, Digipan, MMTTY, MMSSTV, MixW, Ham Radio DeLuxe, and that list could go on, and on. Gone were the days of using op amps and comparators, in came isolation transformers, and opto couplers. I should add I guess that the first OPTO-IF unit I designed used opto couplers to isolate the audio as well as ptt, and cw keying, and quite a few are still working in use today some ten years later.

Have I been around on the interface scene for so long ☺. Yep, and I guess the reason why my units are not household names, is because I don't hype them up, and I don't advertise apart from my web pages. That has changed a little in the last few months since I became the European agent for the US Navigator, a very comprehensive and beautifully built USB soundcard and interface would be putting it mildly. However like other sophisticated pieces of equipment they are not cheap particularly.

In order to provide initially for club project use, I designed the OPTO-IF Kit, and since then there has been quite a few who believe in home brewing their own gear, and who am I to go against that, it is something I have been doing since I became licenced in 1966.

So, onto the project, the **OPTO-IF kit, a fully ground isolated interface** is about to unfold.

The circuitry has been kept simple and straightforward with nothing put in which had no purpose.

To start off with the audio input, and output circuits are identical, based around a pair of 600 ohm data transformers of high quality. No mickey mouse foreign audio transformers of dubious quality here. The input audio is actually named RXAF, because it takes the received audio from your radio, and couples it via a pre set resistor level control to the line, or mic input of your PC's soundcard. The output audio is named TXAF because it couples the audio output from your soundcard, via a pre set resistor for level control to the microphone, or auxiliary input of your radio. As far as Windows is concerned these are the "Recording" and "Playback" sections of your soundcard, and they too obviously have their own level controls which work in tandem with the physical ones on the circuit board.

To achieve ptt for the radio we take the RTS com port signal at RS232 / 485 levels, and use that voltage to drive the light emitting diode inside an opto coupler. Within the opto coupler there is also a transistor, or pair of transistors in darlington configuration. These respond to the light level from the diode, they conduct, and hey presto they sink whatever

is connected to them by way of a voltage down to zero, or 0.2V to be precise. Effectively shorting the ptt contact on the radio, and place it into transmit. In the case of the OPTO-IF kit, they are relatively expensive, high gain, excellent quality Siemens devices.

Two of these opto couplers are used, one for use as the ptt keyer as I mentioned, and the other can be used for one or two functions. The primary design function was to use it to key the radio for CW, in software which had that facility built in. However it can also be used as a switch to provide frequency shift keying or FSK in RTTY. The choice is up to you the user. As a cw keyer it uses the DTR com port signal at RS232 / 485 levels to drive the opto coupler exactly the same as the ptt circuit does, except it effectively grounds your cw key line. Using it as an FSK switch requires it to be driven not from the DTR signal, but from the txd or transmit data signal of the com port. The use of txd to perform this is generic in those software which cater for FSK RTTY.

**The schematic:**

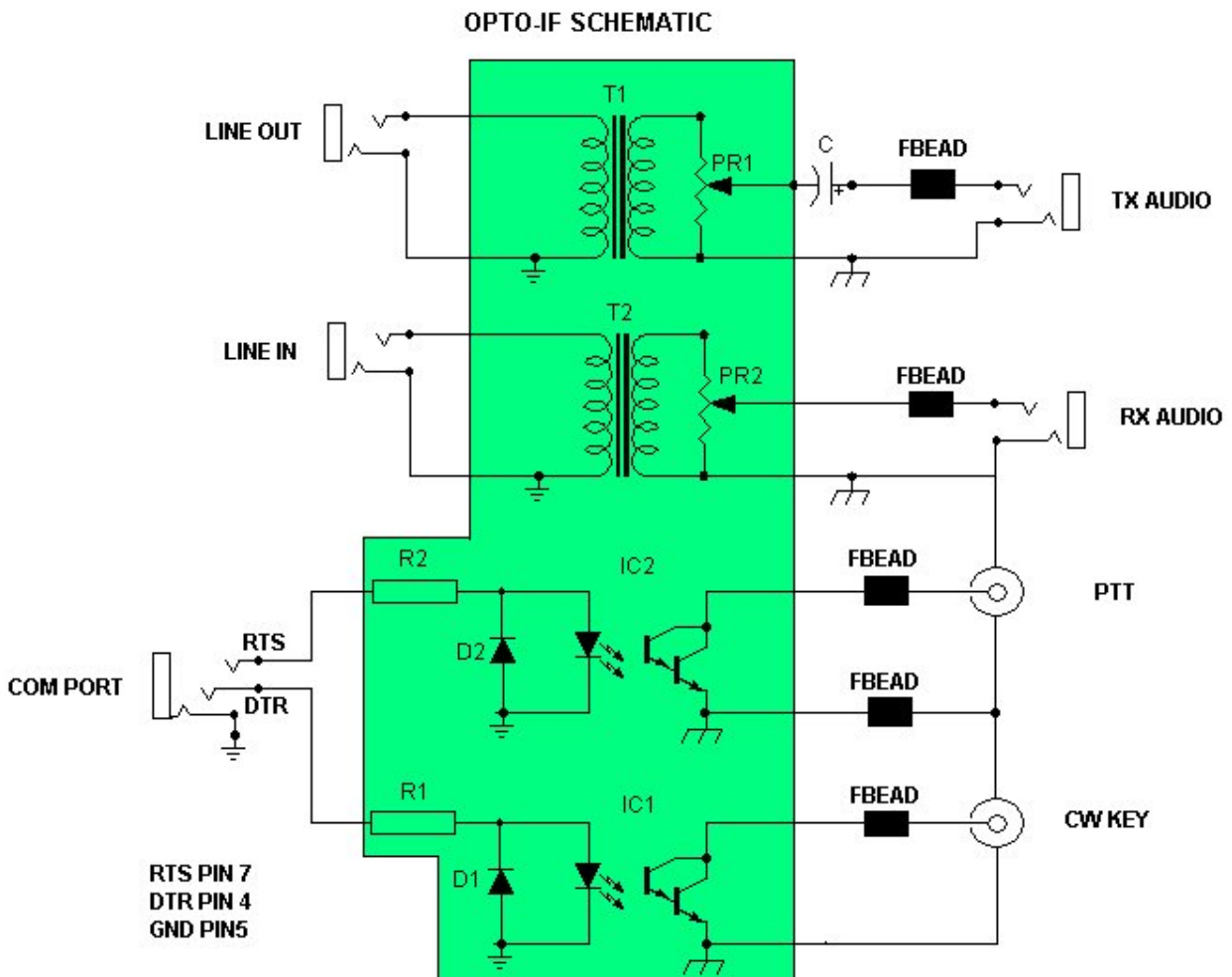

NOTE DTR MAY BE CHANGED FOR FSK USE BY CONNECTING IT TO TXD ON PIN 3 INSTEAD OF PIN 4 ON THE DB9 COM PLUG

C IS A 1MFD ELECTROLYTIC CAPACITOR NOT ON THE PCB, BUT USED IF YOU ARE CONNECTING THE OPTO-IF TO A HANDI TALKIE.

THE COMPONENTS WITHIN THE GREEN AREA ARE THOSE MOUNTED ON THE CIRCUIT BOARD.

Here is the circuit board overlay.

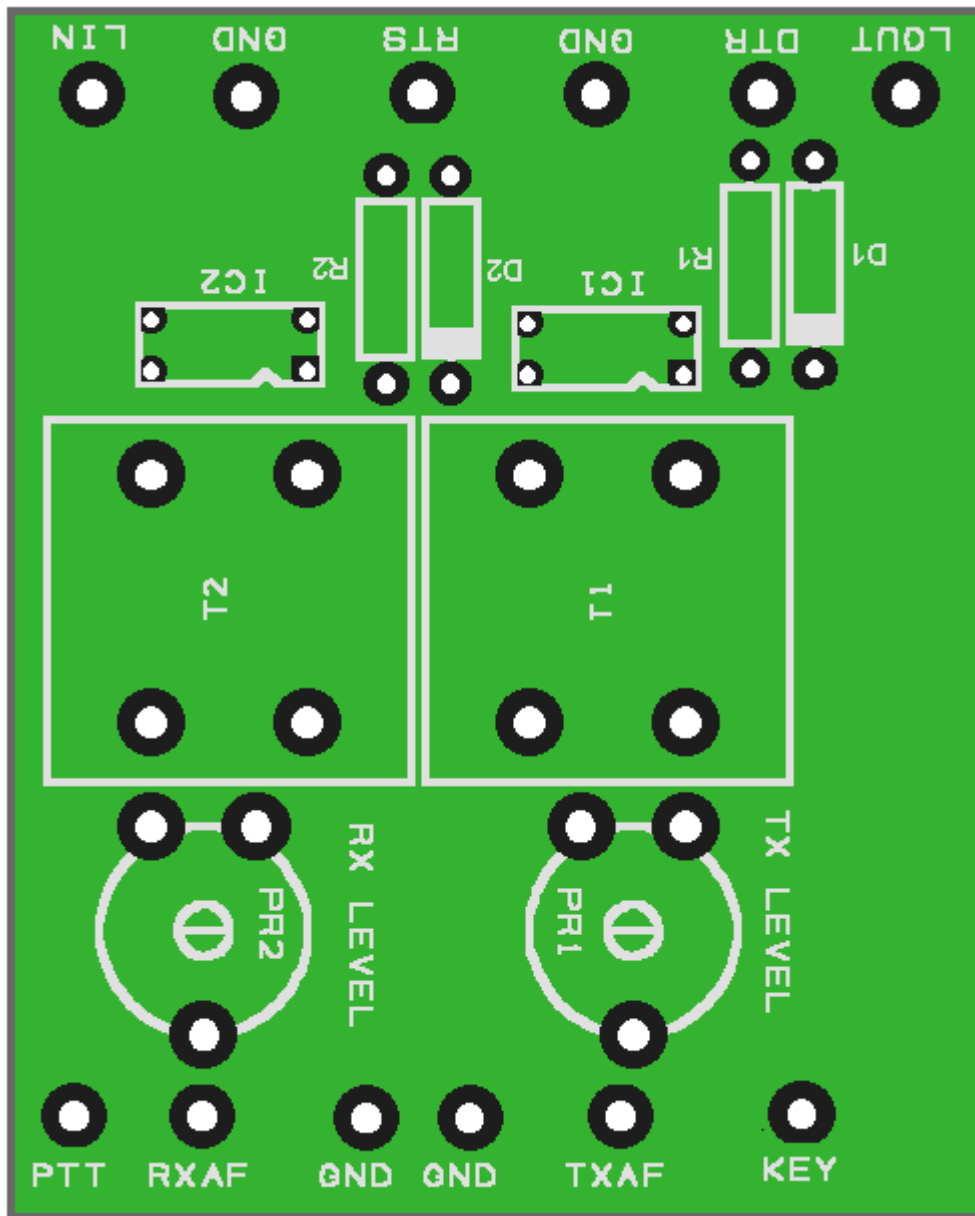

### Components:

R1, R2 = 1K ohm

D1, D2 = 1N4148 Diodes

PR1, PR2 = 100K ohm Pre Sets

T1, T2 = 600 ohm Data transformers

IC1, IC2 = SFH18=A4 Opto Couplers

F BEAD = Ferrite beads slipped over the respective connecting wire.

Note when fitting IC1 and IC2 the square pin on the circuit board is pin 1. That is donated by the notch on the opto coupler itself. Do not solder until you are sure that the opto couplers are the correct way round. The same for the diodes which have a band at their cathode end.

## Interconnections:

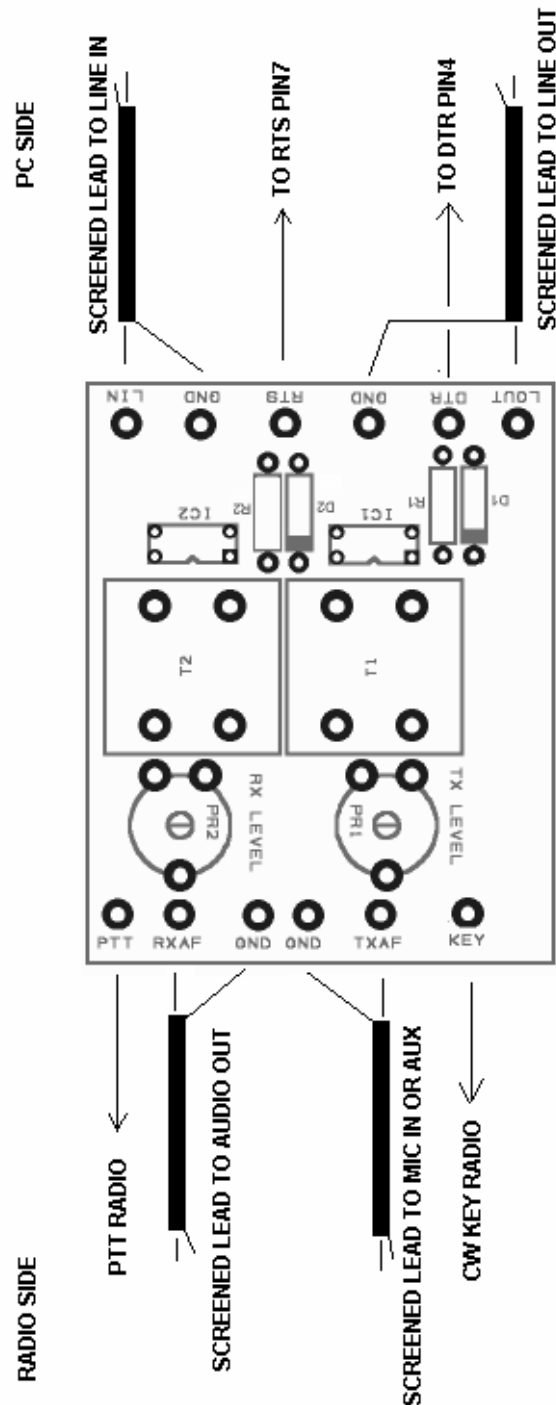

The completed board can be fitted into either a plastic case quite easily, all sockets are provided in the kit which include the 3.5mm jack sockets used for the soundcard in/out, and rx, tx audio. The ptt and cw sockets are the RCA phono type.

Any queries may be answered by email to Dave at the following [ezeuk@blueyonder.co.uk](mailto:ezeuk@blueyonder.co.uk)

Enjoy building your kit. It will last for years I have no doubts, and is as effective in use as any of the commercial interfaces you will find.